

## Compression Cylinder Up-Dates for Floor Level and 1600 Machines

Columbia Machine is trying to streamline our product offerings and supply service parts with the most up to date features, along with be used on today's equipment. With this in mind, we are deleting old design Compression cylinders and replacing them with current design that will fit, form and function. Some of the changes you will see, better cushions with adjustment on extend of cylinder stroke where there was no adjustment before, O-Ring ports instead of pipe thread ports, modern seals in all locations, improving life and leakage control. On the newest cylinder we use a black colored shaft material called Nitro bar. The micro finish on nitro shafting is better and carries the same or better service life over chrome shafting. Now for the best part, because we are using current parts and design the price in most cases will be less than the original and should be in stock or very quickly attainable.

**Example:** If your 16/1600 block machine used 484.2.90 it was deleted to 484.400.3 reasons. We moved away from cast rod end cap with non-adjustable cushion, to a head with adjustable cushion and up-dated seals. Now we have deleted 484.400.3 for our latest design 484.400.12 this cylinder has even better seals. Nitro shafting, improved manufacturing requirements saving you money.

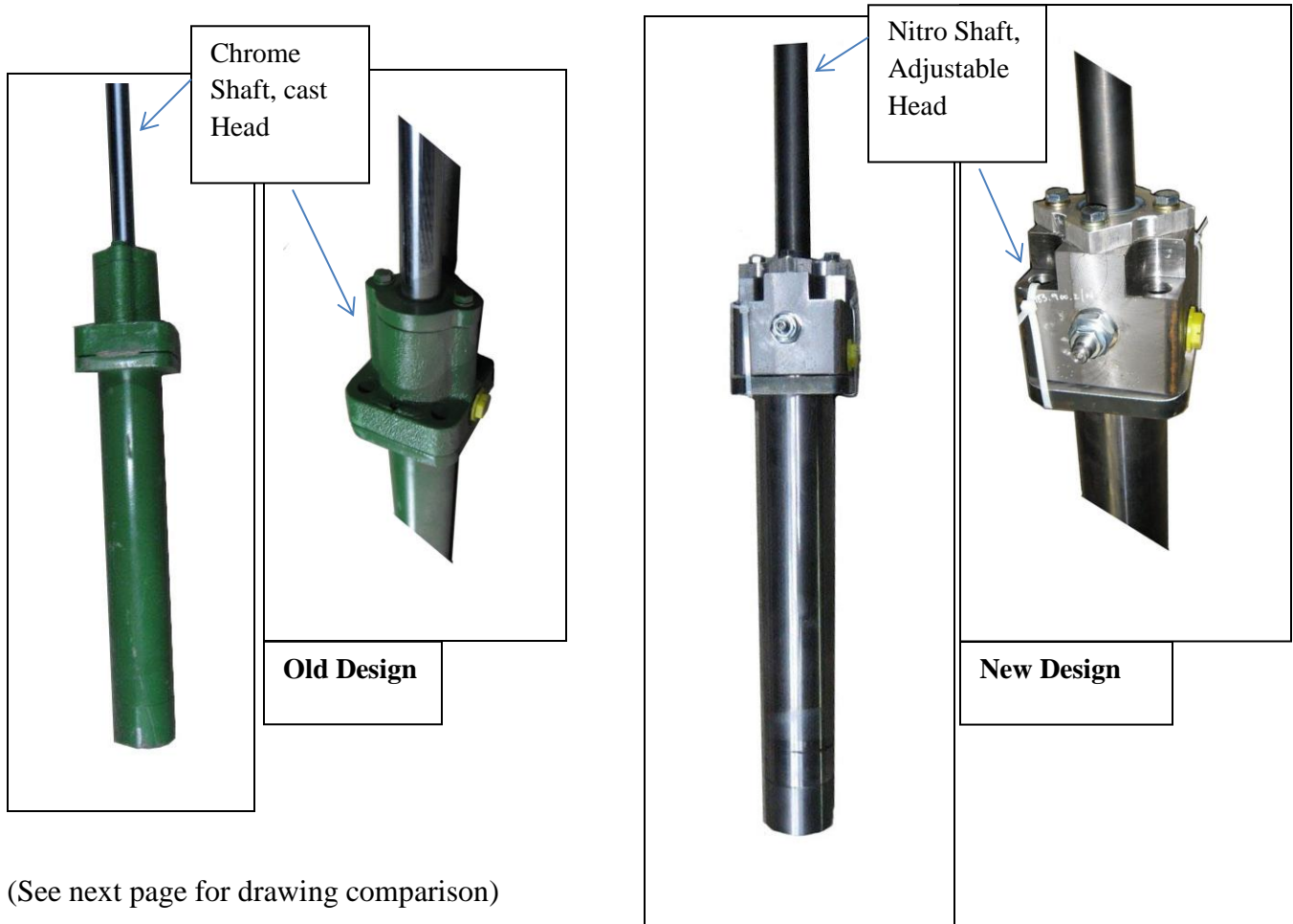

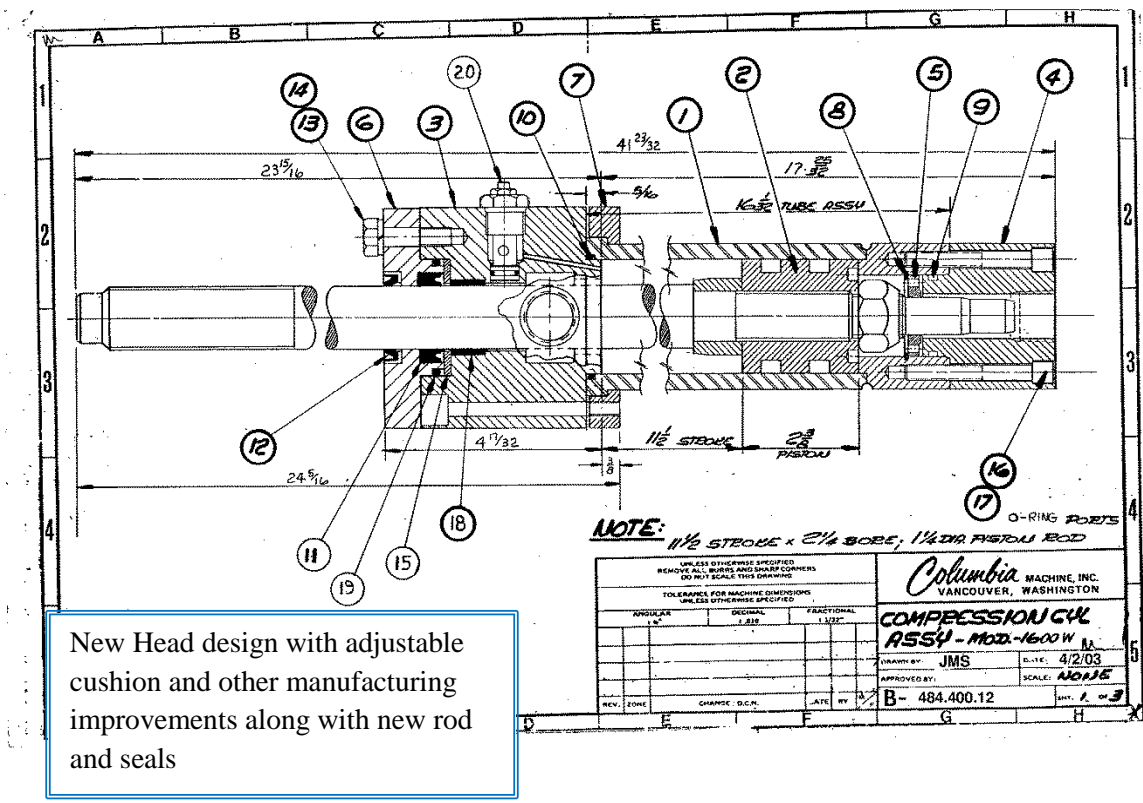
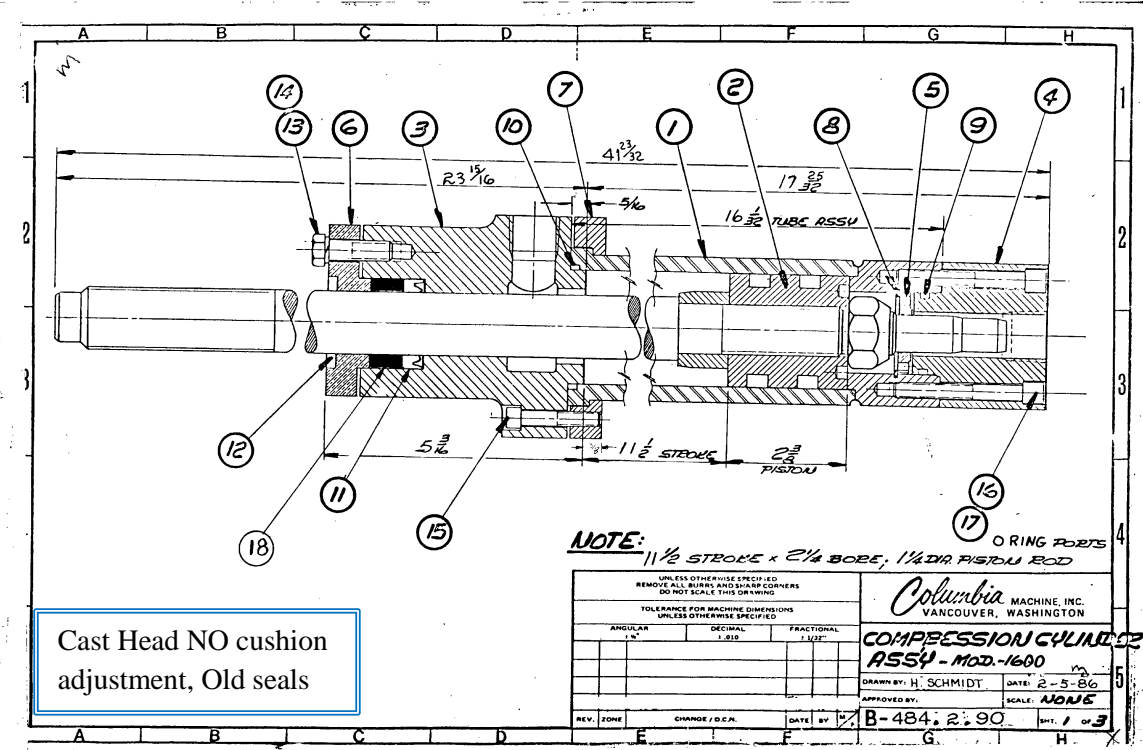

## Reference Table

Old Design	New Design	Machine
484.2.90	484.400.12	16/1600
484.400.3	484.400.12	16/1600
482.1000.20	482.1000.45	22
482.1000.42	482.1000.45	22
	482.1000.58	22 / 2" longer cylinders